

grendel GRENADIER RA-9

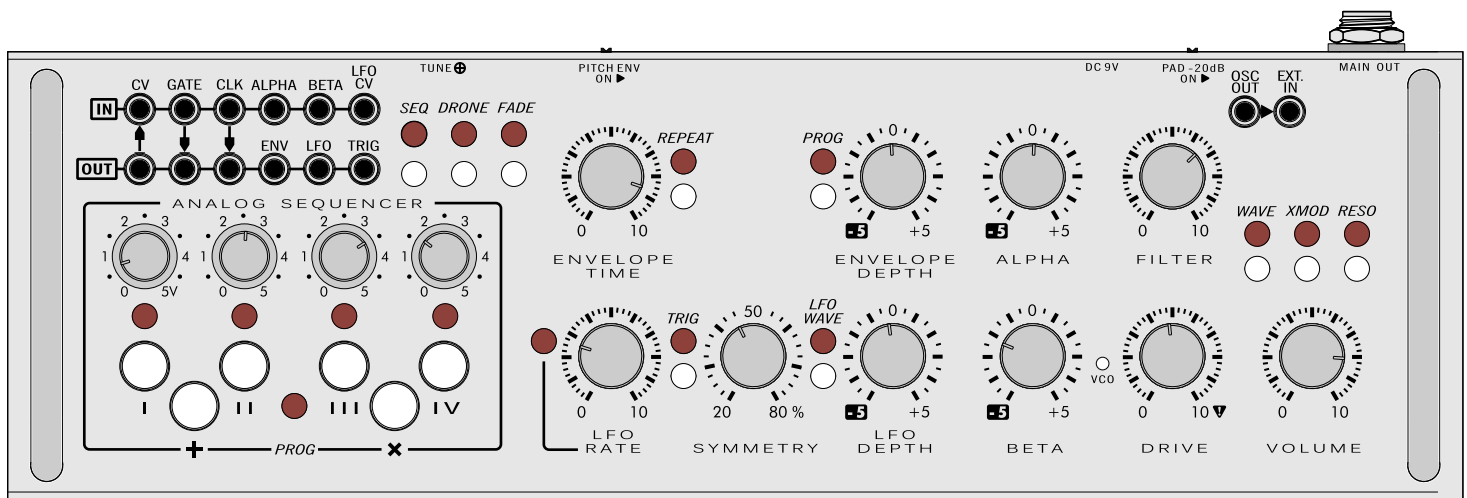

ANALOG MUSIC SYNTHESIZER

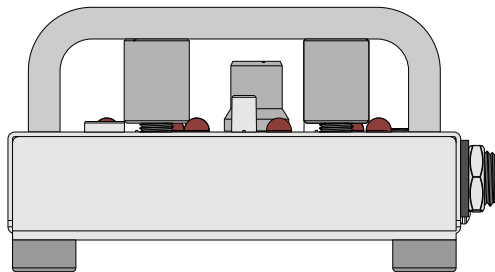

**Rare
Waves**

OVERVIEW



The Grendel RA-9 Grenadier is a monophonic true analog synthesizer with CV-Gate control and a built-in keypad for manual play.

It was designed to seek a balance between simple controls and maximum flexibility while adhering to a strict knob-per-function layout.

Fourteen patch points multiply the creative possibilities for sound manipulation *via* interconnection with other analog equipment.

The Grenadier offers a unique filterbank with three voltage controlled filters in parallel. It can produce a wider range of midrange and low frequency timbres than one filter alone. Vowel effects are possible.

A built-in sequencer can be activated for minimal melodic and rhythmic lines. Connecting a MIDI-CV converter (*not included*) allows you to sequence the Grenadier from a computer music workstation.

The housing is built from tough steel and has a built-in roll cage to protect the control surface.

POWER SOURCE

An AC adapter is required to use the **Grendel RA-9 Grenadier**. There is no internal battery.

The unit is on whenever power is applied. There is no power switch. The Grenadier uses very little power (less than the AC adapter itself). To save electricity, it is wise to unplug the AC adapter when the unit is not in use.

A regulated 9VDC tip-positive AC adapter is supplied with the unit.

The Grenadier is flexible with regard to its DC power source. Nearly any adapter can be used that is rated for 7.5 volts to 12 volts output and has a 2.1mm center pin connector.

- It is **OK** to use tip positive or tip negative power source.
- It is **OK** to use a daisy-chain cable to power the Grenadier from a 9V adapter that is shared with other FX.
- **Don't** connect an unregulated adapter that is rated for more than 500 mA. (If its large and heavy, avoid it)
- **Don't** connect an adapter that is rated for more than 12 volts output.

ATTENTION

TEMPERATURE RESTRICTIONS

Operating outside temperature range of 60-90 °F (16-32 °C) may affect performance. For indoor use. Avoid moisture and high humidity.

FRAGILE - PROTECT FROM IMPACT

Never drop unit onto hard surface. Package carefully with bubble wrap when shipping - don't use newspaper or foam peanuts.

Credits

Eric Archer - hardware and graphics
Nathan Wooster - firmware

Manufactured by

Rare Waves LLC
P.O. Box 729
Llano, TX 78643
United States



CONTROLS

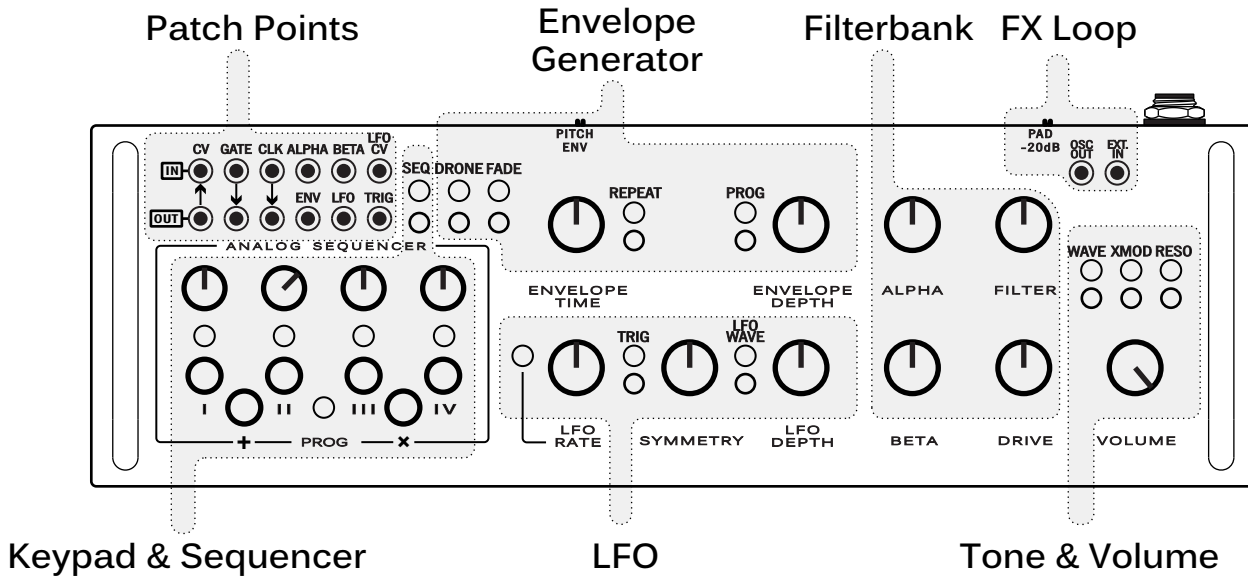

Left-hand side: Pitch and rhythm controls

Right-hand side: Tone and modulation controls

PLAY MODES

SEQ DRONE FADE REPEAT PROG



- **Manual play - Key gate**

The keypad responds like an electronic organ, sustaining a note for as long as the key is pressed down. The envelope generator is triggered by playing the keypad, and its output can modulate the filterbank via the ENVELOPE DEPTH knob.

SEQ DRONE FADE REPEAT PROG



- **Manual play - Fading notes**

The keypad triggers a note with exponential loudness decay. The envelope generator is applied to both VCA and filterbank.

SEQ DRONE FADE REPEAT PROG



- **Steady drone with LFO modulation**

The synthesizer plays a steady tone. Play the keypad to change notes. Apply slow LFO modulation for drone effects.

SEQ DRONE FADE REPEAT PROG



- **Basic analog sequenced VCO with filter envelope**

The sequencer walks from step I-II-III-IV in an endless cycle, producing a melodic sequence with envelope filter effects.

SEQ DRONE FADE REPEAT PROG



- **Programmed rhythm with fading notes**

Fading notes are triggered in a rhythmic pattern. Press PROG-+ to add events, and use PROG-X to erase events. Play the keypad to make pitch transitions. Activate PITCH ENV for bass drops and sound effects.



SEQ DRONE FADE REPEAT PROG



- **Four-note melodic sequence with programmed rhythm**

Fading notes are played in rhythm, changing pitch as the sequencer steps I-II-III-IV in an endless cycle.

Table 1. Reference information for switchable functions

	 OFF	 ON
SEQ	Keypad behaves like a keyboard. Manual (real-time) performance	Analog sequencer steps once per trigger event, endless cycle I-II-III-IV
DRONE	Gate controls VCO output	VCO always on
FADE	VCA always on (no fade-out)	Envelope controls VCA (fade-out)
REPEAT	Keypad / Gate In triggers envelope	Sequencer triggers envelope
PROG	One trigger event per two clocks (steady 1/8 notes)	Programmable trigger loop engaged
TRIG	LFO runs freely	LFO restarts at the beginning of each note
LFO WAVE	LFO generates triangle wave (variable symmetry)	LFO generates square/pulse wave (variable pulse width)
WAVE	VCO generates triangle wave	VCO generates square wave
XMOD	Normal tone	Filterbank modulated by VCO
RESO	Normal tone	Filterbank high resonance and self-oscillation when DRIVE knob = 10
PITCH ENV	Normal tone	VCO pitch bend by envelope
PAD -20dB	Normal external audio level. Best for portable music players	High level external audio input Best for modular systems and pro audio.

VCO



The VCO offers triangle and square waveforms. It covers a frequency range of approximately 20-500 Hz, or 4.5 octaves.

Activate the WAVE switch to select the square wave. The square wave output is pre-filtered internally to emphasize low and upper-mid frequencies.

The VCO's pitch is normally controlled by the tuning knobs I-II-III-IV on the keypad.

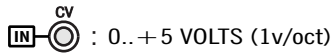

Connecting a patch cable to CV IN overrides the keypad's control of the VCO. However, keypad activity will still be available at CV OUT and can be patched to control other functions.

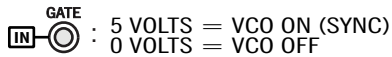

The VCO responds directly to GATE. When GATE is off, the VCO is disabled (silent).

The VCO is synced (reset to reference phase) by the GATE signal. This gives better low-frequency output with staccato sequences.

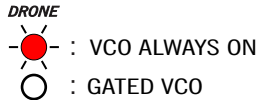

Activate the DRONE switch to hold GATE on for continuous sound. When DRONE is on, the VCO continues to produce tone regardless of the GATE IN and keypad buttons. Also turn off FADE for endless drones.

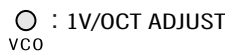

The VCO follows the 1 v/oct standard. It responds to CV input in the range of 0..+5 volts. Voltages outside this range are ignored. The scale response can be trimmed with the VCO trimmer. Insert a small flat or Phillips screwdriver through the opening. It is a single-turn type trimmer.



Fine-tuning the VCO is possible with the TUNE trimmer. Insert a small flat or Phillips screwdriver to adjust TUNE. It is a single-turn type trimmer. The fine tuning range is slightly greater than one octave. Adjusting this control is recommended when using a MIDI-CV converter. This will allow you to put the Grenadier in tune with other synthesizers in your system.

KEYPAD



The keypad is active when the SEQ switch is off. The Grenadier's keypad can be played in real time like the keys on a keyboard. This makes it easy to experiment with phrases and jam along with a beat.

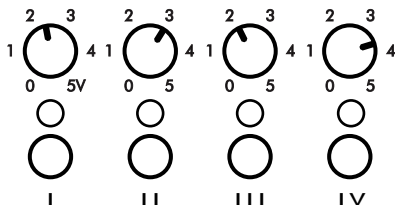

The keys are numbered I-II-III-IV. Above each key is a knob that sets its pitch. You can adjust these knobs to tune the keys to notes from a scale that fits your composition.

The keypad remembers the last key that was pressed and the VCO will continue to sound that pitch if the DRONE switch is on, or if GATE IN is active.

The CV OUT patch point sends analog voltage corresponding to the active key. The range of output is 0..+5 volts. The GATE OUT patch point is active whenever a key is pressed. You can use the Grenadier's keypad to control another CV-Gate synthesizer by patching CV OUT and GATE OUT to it.

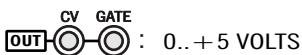

SEQUENCER

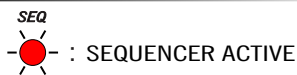

When the SEQ switch is on, the analog sequencer is active. The LEDs above the keys I-II-III-IV will cycle automatically in a loop from left to right.



The Grenadier's LFO supplies clock to the analog sequencer. You can supply an external clock to the sequencer by connecting it to the CLK IN point. Typically, a 16th-note square wave clock is recommended. The external clock should be a 5 volt square wave (0..+5 volts). The sequencer steps on the rising edge.

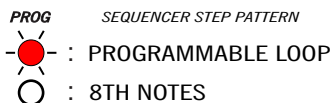

The rhythm pattern of the analog sequencer is controlled by the PROG switch.

- When PROG is off, the sequencer will step once for every two clock transitions (half time or 8th notes).
- When PROG is on, the sequencer will step once for each trigger event in the programmable loop.

The next page explains how to use the programmable trigger loop for interesting rhythmic sequences.

SEQUENCER

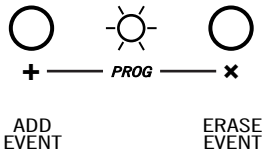
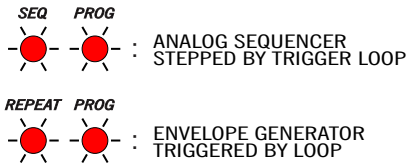

The Grenadier's programmable sequencer generates trigger pulses in a 32 step (2 bar) endless loop.

To step the analog sequencer with the trigger loop, SEQ and PROG switches.

To trigger the envelope generator with the trigger loop, activate the REPEAT and PROG switches.

The sequencer is controlled by the PROG+ and PROG-X buttons. The LED between the buttons flashes to visually indicate the programmed pattern.

Set the LFO (or external clock) for a 16th-note tempo. *If the LFO is very slow, or if there is no valid clock signal patched to CLK IN, the sequencer will appear inoperable.*

Erase the old sequence by pressing and holding PROG-X while tapping PROG+.

Add trigger events to the loop by tapping rhythmically on the PROG+ button. After 2 bars (or 32 clock cycles), the LED will begin flashing the recorded pattern. It is quantized to match the clock. In other words, you can't program notes faster than the clock rate. *It is not possible to change the loop length.*

Erase unwanted trigger events by pushing PROG-X over the event as it comes around. You can erase a longer portion of the sequence by holding down the PROG-X button like an eraser.

Press and hold PROG+ while tapping PROG-X to make the sequencer play a steady 16ths note roll (one event per clock cycle). Tap the buttons again to get out of roll mode. **Use this function if you want to trigger the Grenadier from an external rhythm machine.**

Once you have created an interesting rhythm pattern, try alternating the PROG switch (near ENVELOPE) to switch back and forth between metronomic 8th notes and your programmed pattern.

The sequencer can trigger external modules from the TRIG OUT patch point.

When SEQ is on, the analog sequencer always steps in order I-II-III-IV, repeating from step I... it is not possible to program the sequencer to play in a different order. Use CV-Gate control instead for complex patterns.

FILTERBANK

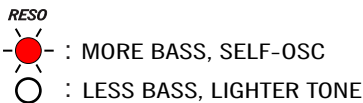
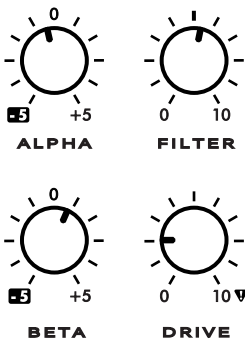

The Grenadier's filterbank contains three voltage controlled bandpass filters working in parallel.

The filterbank processes the VCO's output. It is also capable of being a signal source of its own - it can be set to generate low frequency self-oscillations. This can be useful for percussion effects.

Use the ALPHA, BETA, FILTER, and DRIVE knobs to modify the frequencies that the filterbank emphasizes and sculpt interesting tones.

The FILTER knob affects the overall frequency range of the filterbank. It adjusts all three VCFs in parallel.

The ALPHA and BETA knobs primarily affect the positions of the midrange resonators and affect the color of modulations from the LFO and Envelope Generator. ALPHA and BETA are bipolar controls. The normal position for ALPHA and BETA is zero, located at 12 o'clock.

Patching a CV source to ALPHA IN or BETA IN will modulate the filterbank. The full range of control is 0..+5 volts. *External LFOs with bipolar (+/-) output may not behave as expected.*

The DRIVE knob mainly affects the low-frequency qualities of the signal. If the RESO switch is on, self-oscillation will occur when DRIVE is set to maximum position. The self-oscillation is accompanied by overdrive distortion in the filterbank. The volume level can increase significantly when self-oscillation sets in.

The filterbank can process external audio via the EXT IN patch point. For this purpose, cancel the internal VCO by plugging a dummy cable into OSC OUT. Use the PAD -20dB switch if the external signal overdrives the filterbank, such as from a modular VCO or +4dBu mixing desk line output.

Note that the filterbank is not designed for full cutoff (hi-pass or low-pass). Instead, it is designed to emphasize low and mid frequencies in a way similar to a vowel formant filter. Therefore, setting the FILTER knob to its extremes will still allow some sound through.

LFO

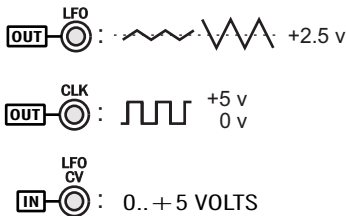
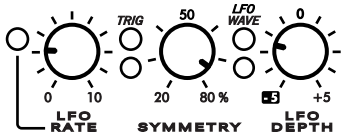
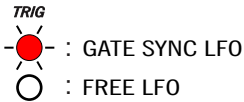
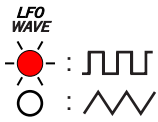

The LFO modulates the filterbank and also serves as the clock source for the Grenadier's sequencer.

The LFO offers triangle and square wave output. Activate the LFO WAVE switch to select square wave.

An LED flashes in time with the LFO. The LFO frequency range is approximately 0.05 Hz to 60 Hz.

The TRIG switch can make it appear that the LFO cycles are synchronized with the tempo of the music.

- When the TRIG switch is off, the LFO runs freely.
- When the TRIG switch is on, the LFO is reset when the keypad is pressed, or when the GATE IN patch is active.

The SYMMETRY knob affects the LFO's triangle wave by varying its ratio of rise time to fall time. It also affects the duty cycle of the square wave in the range of 20% to 80%. The normal position of the SYMMETRY knob is 12 o'clock. This control also has a slight effect on the LFO frequency.

The LFO DEPTH knob is used to modulate the filterbank. It is a bipolar control. To cancel LFO modulations, the LFO DEPTH knob should be set near 12 o'clock. *Listen carefully - the exact position for zero modulation can be tricky to find, and may not correspond perfectly with the indicator at 12 o'clock.*

LFO DEPTH works in conjunction with the BETA knob, affecting the filterbank the same as if you were manually turning the BETA knob.

The LFO's waveform is available at the LFO OUT patch point. Its voltage range is approximately +1..+4 volts. The LFO OUT patch point is post-LFO DEPTH.

CLK OUT sends raw square wave LFO output.

The LFO rate can be modulated over a wide range by patching a control voltage to the LFO CV IN patch point. It has exponential frequency control, but not 1v/oct.

ENVELOPE AND VCA

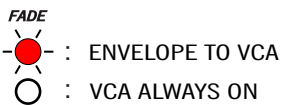
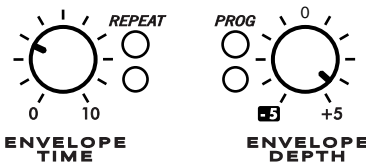

The Grenadier's envelope generator is of the exponential decay type. The ENVELOPE TIME knob adjusts the length of the decay. Very long decay times (>1 min) are possible when this knob is set to 10.

When the REPEAT switch is off, the envelope is triggered by playing the keypad (or GATE IN).

When the REPEAT switch is on, the envelope is triggered automatically. The trigger pattern will depend on the position of the PROG switch and the programmed loop in the sequencer.

- When PROG is off, the trigger pattern is regular metronomic pulses at 1/2 the rate of the LFO.
- When PROG is on, the programmed loop triggers the envelope.

Use the ENVELOPE DEPTH knob to apply the envelope to the filterbank. This is a bipolar control. To cancel filterbank modulation, ENVELOPE DEPTH should be set near its 12 o'clock position. ENVELOPE DEPTH works in conjunction with the ALPHA knob to control the filterbank timbre.

Activate the FADE switch to apply the envelope to the VCA. This makes the tone fade away to silence. For full fade-out, the DRONE switch should also be on.

Turn on the FADE, DRONE, SEQ, REPEAT, and PROG switches for a sequenced melody effect.

The rear-panel slide switch PITCH ENV ON applies the envelope to modulate the VCO pitch. Adjusting ENVELOPE DEPTH will vary the pitch envelope from rising to falling. This can make pitched bass drops, as well as other sound effects.

Use the ENV OUT patch point to control other functions or CV inputs on external equipment. The range of voltages is approximately +1 .. +4 volts. The ENV OUT is post-ENVELOPE DEPTH knob.

TONE AND VOLUME

WAVE



The controls on the right-hand side of the Grenadier affect tone and volume.

The WAVE switch chooses between triangle and square wave from the VCO.

XMOD

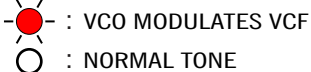

The XMOD switch applies the VCO waveform to modulate the filterbank cutoff frequency.

RESO

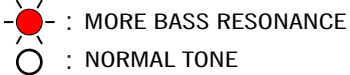

The RESO switch converts one of the filterbank's three VCFs to lowpass mode and increases its Q-factor. When RESO is active, the low frequency output will increase, and self-oscillation begins when the DRIVE knob is rotated to near its maximum position.

 *Activating RESO and turning DRIVE to 10 will increase the output volume with heavy low-frequency distortion.*

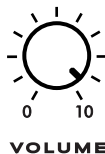

VOLUME is an attenuator for the Grenadier's main output.

The main output is a 1/4" mono phone jack. Use a guitar cable or any shielded instrument cable.

Connect MAIN OUT to an instrument amplifier, FX pedal, FX processor, mixing desk line input, -10dB tape input, computer sound card input, microphone preamplifier, or Hi-Z DI box for stage use when FOH is far away.

PATCH POINTS

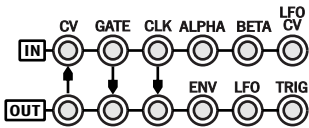

The Grenadier has 14 patch points for connecting analog signals between its own modules, another Grenadier, MIDI-CV converter, or some Eurorack modules.**

** All of the Grenadier's patch points are designed to operate within a voltage range of 0..+5 volts. Voltages outside this range are limited by the internal protection circuitry. Negative voltages have the same effect as 0 volts. Voltages more positive than +5 volts are limited to +5 volts. Never apply voltage above +15 or below -15 volts. Never connect an external module's output to a Grenadier output.

The patch points are designed for 3.5mm (1/8") mono phone plugs, such as Eurorack patch cords. Shielded cable is not essential but may improve sound quality when patching audio to EXT IN.

All of the jacks on the top row are inputs. All of the jacks on the bottom row are outputs.

Connect a MIDI-CV converter to CV IN and GATE IN. If there are auxiliary CV outputs, such as mod wheel or expression, try patching these to ALPHA IN, BETA IN, or LFO CV IN.

A MIDI-CV converter's analog clock output can be patched to CLK IN. This is normally a square wave signal at 16th note intervals. (DIN SYNC is not supported unless you use a DIN SYNC-to-clock converter.)

The OSC OUT and EXT IN patch points can be used as an effects insert point, or to mix in external audio for processing through the Grenadier's filter. Inserting a patch cord into OSC OUT cancels the connection of the VCO to filterbank.

The signal levels of OSC OUT and EXT IN are compatible with FX pedals, portable audio players, and -10dBu consumer equipment. In some cases you will need to add gain to the signal with external equipment.

The PAD -20dB switch is an attenuator for the EXT IN jack. Activate the pad if unwanted distortion is heard when processing external audio. Using an external preamp or buffer pedal is suggested when connecting guitar or bass guitar to EXT IN.

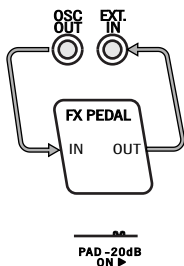
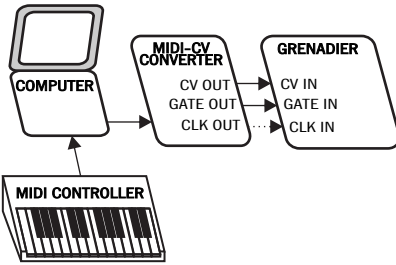

SYSTEM DIAGRAM

Diagram 1. Grenadier internal signal flow including patch points. Open arrows (→) indicate a connection that is broken when a plug is inserted.

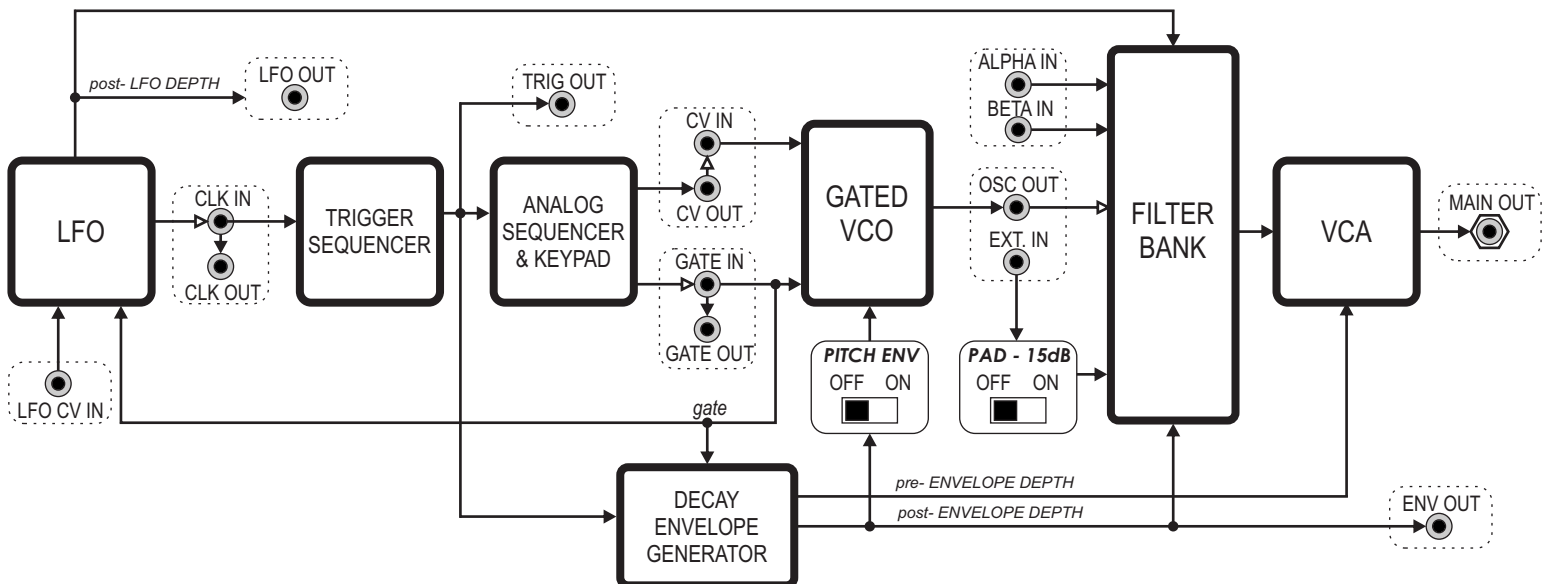

VCO Tuning Method # 1 - Using a voltmeter and A440 reference

This is a fast and accurate way to tune the VCO. It requires a digital voltmeter and a pitch pipe or tuner with A440 tone output.

Getting ready

- Power on the Grenadier for 30 minutes before beginning the procedure.
- Locate a small screwdriver suitable for adjusting the Grenadier's TUNE and VCO trimmers.
- Locate a digital volt meter (DMM) with 3.5 digits precision or better. Connect the DMM to the Grenadier's CV OUT patch point. You can use a pair of alligator clips to make connection between the DMM's test probes and a patch cable. Connect the patch cable's tip to the DMM's red probe, and the patch cable sleeve to the black probe.
- Turn DRONE on. All other switches should be off, including PITCH ENV. Set LFO DEPTH to zero (12 o'clock). The Grenadier should be sounding a steady tone without modulation.
- Give the Grenadier's TUNE and VCO trimmers some exercise for cleaning purposes. Do this by rotating them from one end to the other two or three times. These are single turn trimmers.

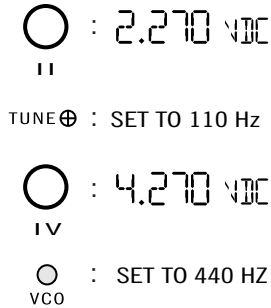
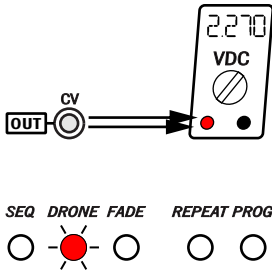

Procedure

1. Sound A440 reference with the pitch piper or tuner.
2. Press the **II** key and set the knob above it so the DMM reads 2.270 volts DC.
4. Adjust the TUNE trimmer so the Grenadier's pitch sounds exactly 2 octaves below the reference.
5. Press the **IV** key and set the knob above it so the DMM reads 4.270 volts DC.
6. Adjust the VCO trimmer so the Grenadier's pitch matches the reference.

As further verification, you can set the **I** key to 1.270 volts and the **III** key to 3.270 volts. Now all four keys **I-II-III-IV** should play a sequence of ascending octaves in tune with the reference.

Note that at 2.270 volts, the VCO's pitch is independent of the VCO trimmer setting.

Final adjustment

7. Use a MIDI keyboard to control the Grenadier by patching your MIDI-CV converter to the Grenadier's CV and Gate inputs.
8. Play a pitch of "A" on the MIDI keyboard. Listen to the Grenadier's audio and adjust its TUNE trimmer so it sounds in tune with the reference pitch.

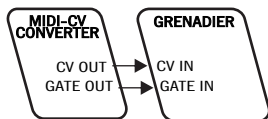

Now your Grenadier will play in tune with a synthesizer ensemble controlled by your MIDI workstation and MIDI-CV converter.

You may need to octave transpose MIDI parts from your existing compositions so they will sound correct on the Grenadier.

VCO Tuning Method # 2 - Using a MIDI-CV converter and MIDI keyboard

This is the quick-and-dirty method of tuning the VCO. The accuracy of its results are limited by your pitch perception and monitoring environment.

Getting ready

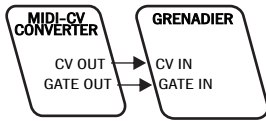

- Power on the Grenadier for 15 minutes before beginning the procedure.
- Locate a small screwdriver suitable for adjusting the Grenadier's TUNE and VCO trimmers.
- Turn DRONE on. All other switches should be off, including PITCH ENV. Set LFO DEPTH to zero (12 o'clock). The Grenadier should be sounding a steady tone without modulation.
- Connect your MIDI-CV converter to the Grenadier's CV IN and GATE IN. Connect a MIDI keyboard or workstation to the converter.

Procedure

1. Pick two notes one octave apart on the MIDI keyboard. Use the middle of its pitch range. Play these notes alternately while listening carefully to the Grenadier's pitch.
2. Adjust the VCO trimmer so the Grenadier is sounding notes exactly one octave apart.
3. Now play a repeating sequence of octave-spaced notes over a wider range, such as A₁-A₂-A₃-A₄. Listen carefully to the Grenadier's output and adjust the VCO trimmer carefully so it is playing true octaves.

○ : 1V/OCT ADJUST
VCO

Final adjustment

4. Set the MIDI keyboard to control another synthesizer which you know is already in tune.
5. Play middle C on the external synthesizer and sustain the note.
6. Play middle C on the Grenadier and adjust its TUNE trimmer to match the pitch of the external synth.

TUNE ⊕ : FINE TUNE

Now your Grenadier should play in tune with an ensemble of instruments controlled by your MIDI workstation and MIDI-CV converter.

You may need to octave transpose MIDI parts from your existing compositions so they will sound correct on the Grenadier.

VCO Tuning Method # 3 - Using a voltmeter, MIDI-CV converter, and A-440 tone source

This is a fast and accurate way to tune the VCO when you have a MIDI workstation and MIDI-CV converter. It requires a digital voltmeter and a tuner with A440 tone output. The results will be in tune regardless of any 1V/octave scale inaccuracy within your MIDI-CV converter.

Getting ready

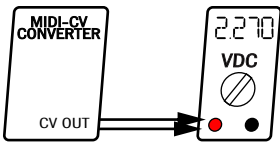

- Power on the Grenadier for 30 minutes before beginning the procedure.
- Locate a small screwdriver suitable for adjusting the Grenadier's TUNE and VCO trimmers.
- Locate a digital volt meter (DMM) with 3.5 digits precision or better. Connect the DMM to the MIDI-CV converter's CV output. You can use a pair of alligator clips to make connection between the DMM's test probes and a patch cable. Connect the DMM's red probe to the patch cable's tip, and the black probe to the patch cable sleeve.
- Turn DRONE on. All other switches should be off, including PITCH ENV. Set LFO DEPTH to zero (12 o'clock). The Grenadier should be sounding a steady tone without modulation.
- Give the Grenadier's TUNE and VCO trimmers some exercise for cleaning purposes. Do this by rotating them from one end to the other two or three times. These are single turn trimmers.

Procedure

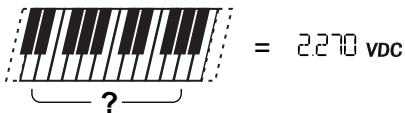

1. Find the key on your MIDI controller which produces an reading of 2.270 volts DC on the voltmeter. *If it doesn't read exactly 2.270 volts, select the key that is approximately closest.* Remember this key - it is your reference note.
2. Disconnect the voltmeter from the MIDI-CV converter.
3. Patch the MIDI-CV converter to the Grenadier's CV IN. Play the reference note on the MIDI controller.
4. Listen to the A-440 tone from your tuner and compare it to the Grenadier's pitch.
5. Adjust the TUNE trimmer so the Grenadier's pitch sounds exactly 2 octaves below A-440 Hz.
6. On your MIDI controller, now play the key that is located 2 octaves above the reference note.
7. Adjust the VCO trimmer so the Grenadier's pitch is in unison with the A-440 tone.

TUNE ⊕ : SET TO 110 Hz

○ : SET TO 440 HZ
VCO

Note that this procedure works because at 2.270 volts, the VCO's pitch is independent of the VCO trimmer setting.

If you have a frequency counter in your modular setup, you can skip listening to the A440 tone reference. Connect OSC OUT to the frequency counter's input. Use the frequency counter to find your target of 110 Hz at step 5, and 440 Hz in step 7... fast, silent, accurate tuning.

Final adjustment

8. Play an "A" note on your MIDI controller. Compare the Grenadier's pitch to the A-440 tone.
9. Adjust the TUNE trimmer so the Grenadier is playing a pitch of A in unison (or perfect octave interval).

If you practice this procedure several times it will become a painless and intuitive way to put the Grenadier in tune with your other instruments at the beginning of a session.

Hint: If you remember the reference note for 2.270 volts output from your MIDI-CV converter, you can begin at step 3 next time - and you won't need the voltmeter any more.

PATCH SPECS

Table 2. Grenadier patch points technical data

Block	Name	Description	Internal normal patch	Working voltage	Working impedance	Limiter impedance
Sequencer	CV OUT	Keypad and sequencer control voltage output		0 .. +5 V	150 Ω	150 Ω
	TRIG OUT	Programmable trigger sequencer output		0 V (off), +5 V (on)	150 Ω	150 Ω
	GATE OUT	Keypad gate output	acts as thru of GATE IN	0 V (off), +5 V (on)	300 Ω	150 Ω
	CLK IN	Clock input to sequencer	normaled to CLK OUT	0 V (low), +5 V (hi)	150 Ω	150 Ω
VCO	CV IN	VCO frequency control voltage input	normaled to keypad CV OUT	0 .. +5 V	10 kΩ	150 Ω
	GATE IN	VCO gate input (VCO enable)	normaled to keypad GATE OUT	0 V (off), +5 V (on)	10 kΩ	150 Ω
	OSC OUT	VCO audio oscillator w aveform output	half-normaled to VCF input	2.5V +/- 2.0V	1 kΩ	1 kΩ
Envelope	ENV OUT	Control voltage output from decay envelope generator		2.5V +/- 2.0V	150 Ω	150 Ω
LFO	CLK OUT	Clock signal from LFO, square/pulse w ave	acts as thru of CLOCK IN	0 V (low), +5 V (hi)	300 Ω	150 Ω
	LFO OUT	Control voltage output from LFO (tri/pulse w ave)		2.5V +/- 1.2V	150 Ω	150 Ω
	LFO CV IN	LFO frequency control voltage input		0 .. +5 V	10 kΩ	150 Ω
Filterbank	ALPHA	Control voltage input to Formant Processor Alpha parameter	normaled to ENV OUT	0 .. +5 V	15 kΩ	150 Ω
	BETA	Control voltage input to Formant Processor Beta parameter	normaled to LFO OUT	0 .. +5 V	15 kΩ	150 Ω
	EXT IN	External audio input to filterbank, AC-coupled		-5 .. +5 V	110 kΩ	no limiter
Line Out	MAIN OUT	Master audio output, 1/4", AC-coupled		0V +/- 2V	604 Ω	no limiter

Limiter is engaged when input exceeds working voltage range.

SPECIFICATIONS

Brand Grendel
Model RA-9 Grenadier

Power Source AC adapter
Adapter Voltage 7.5 - 12 VDC, 100mA nominal
Power Source Polarity Accepts tip negative or tip positive
Protection Internal voltage regulator, self-resetting fuse
Battery NO

Audio Output 1/4" mono
Output Line Level -10 dBu

Technology Analog surface mount
Synthesis Topology Subtractive synthesis - all analog
Polyphony 1 Voice (monophonic)
Functions Included 1xVCO, 1xVC-LFO, 1xDecayEG, 1xFilterbank (3 BPF), 1xVCA, Sequencer, Keypad
Physical Controls 14 rotary knobs, 12 switches, 6 buttons

CV-Gate IN/OUT YES
MIDI IN/OUT NO
USB IN/OUT NO

Patch Points 14 total
Patch Cable Type 1/8" (3.5mm) mono phone plug
CV IN Format 1 volt/octave
GATE IN Format 0V=off, +5V=on
Voltage Range - All Inputs/Outputs 0..+5 volts
Input/Output Protection 150-ohm limiter for input outside working voltage range

Dimensions 11.5" W x 4" D x 2.5" H (29 x 10 x 6.3 cm)
Mass (minus power source) 1lb 15 oz (0.875 kg)

Origin Assembled in USA

SERVICE

For technical inquiries and service information:

Service@RareWaves.net

